

Fireside Chat



FREIGHTLINER CUSTOM CHASSIS | Driven By You

Agenda

*Fireside
Chat*

- ▶ [Introduction to FCCC](#)
- ▶ [Chassis Family](#)
- ▶ [Ownership Experience](#)
- ▶ [Let's Drive!](#)
- ▶ [Chassis Care](#)
- ▶ [Freightlineage](#)



FREIGHTLINER CUSTOM CHASSIS | Driven By You

Introduction to FCCC

[Introduction to FCCC](#)

[Chassis Family](#)

[Ownership Experience](#)

[Let's Drive!](#)

[Chassis Care](#)

[Freightlineage](#)



Our Heritage

*Fireside
Chat*

DAIMLER

FREIGHTLINER®

Custom Chassis



FREIGHTLINER CUSTOM CHASSIS | Driven By You

About FCCC

*Fireside
Chat*

- ▶ Located in Gaffney, SC
 - 55 miles southwest of Charlotte, NC
- ▶ 900+ employees, average 11 yrs.
- ▶ 150,000 chassis capacity annually
- ▶ Customer Driven: **Driven by You**



FREIGHTLINER CUSTOM CHASSIS | Driven By You

Industries Served Outside of RV

*Fireside
Chat*

- ▶ **Delivery Truck**
 - World's largest manufacturer of walk-in van chassis
- ▶ **Commercial Bus**
 - 25% market share in Commercial Bus market
- ▶ **School Bus**
 - Provided exclusively to Thomas Built Buses, the industry leader



FREIGHTLINER CUSTOM CHASSIS | Driven By You

Chassis Family

[Introduction to FCCC](#)

[Chassis Family](#)

[Ownership Experience](#)

[Let's Drive!](#)

[Chassis Care](#)

[Freightlineage](#)



XC: Industry Leader

*Fireside
Chat*

- ▶ XC is a Rear Engine Chassis 450HP or under
- ▶ More than 70% of all Class A diesel motorhomes ride on XC
- ▶ Diesel Engines
 - Cummins B6.7 & L9



FREIGHTLINER CUSTOM CHASSIS | Driven By You

Premium Appointments

*Fireside
Chat*

▶ Front Axles

- I-Beam: 55-degree wheel cut
- Independent suspension: 60-degree wheel cut



▶ Standard Front Disc Brakes

▶ V-Ride



▶ UltraSteer



▶ OptiView



▶ RoadWatch



FREIGHTLINER CUSTOM CHASSIS | Driven By You

Formed Rail

*Fireside
Chat*

- Formed Rail for Lower Engine
- Customizable Rail Configurations

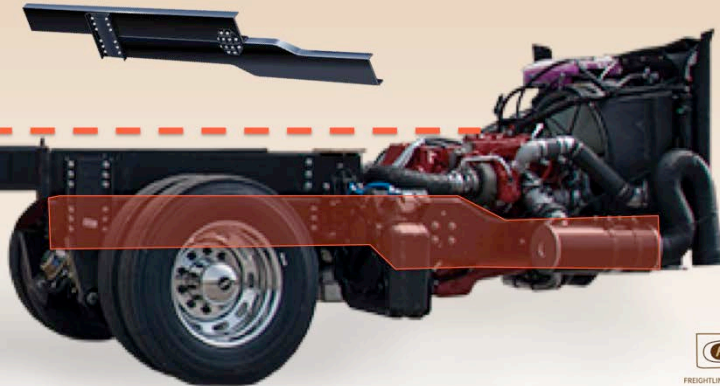

XCS Straight Rail

*Fireside
Chat*

Advantage:

- ▶ Lower to the ground

Benefit:

- ▶ Ease of Entry



300XCS

360XCS

340XCS

V **RIDE**
REAR SUSPENSION SYSTEM



FREIGHTLINER CUSTOM CHASSIS | Driven By You

XCR Raised Rail

*Fireside
Chat*

Advantage:

- ▶ Raised Rail increased basement ceiling height.

Benefit:

- ▶ Increased basement storage



400 XCR

450 XCR

V **RIDE**
REAR SUSPENSION SYSTEM

ULTRA **STEER**



FREIGHTLINER CUSTOM CHASSIS | Driven By You

XCL Lowered Rail

*Fireside
Chat*

Advantage:

- ▶ Lowering the rails provides a lower center of gravity and moves the rails underneath the basement

Benefit:

- ▶ Lower rails offers an increased storage



400XCL
450XCL

V **RIDE**
REAR SUSPENSION SYSTEM

ULTRA **STEER**



FREIGHTLINER CUSTOM CHASSIS | Driven By You

XCM Modular Rail

*Fireside
Chat*

Advantage:

- ▶ Bridge structure

Benefit:

- ▶ Like a bridge, modular frames get their rigidity from an engineered truss structure, which allows for increased basement storage.



360 XCM

450 XCM

380 XCM

ULTRA STEER

400 XCM

V RIDE
REAR SUSPENSION SYSTEM



FREIGHTLINER CUSTOM CHASSIS | Driven By You

SL: Superior Luxury

*Fireside
Chat*

▶ ISX12, X15 or DD13 with Virtual Technician



▶ ZF Independent Front Suspension



▶ Up to 20,000 lb. Front Axle

▶ Up to 14,000 lb. Tag Axle

- Industry-leading 12-degree passive steer

▶ V-Ride Rear Suspension



▶ UltraSteer Tag Suspension



▶ OptiView



▶ RoadWatch



FREIGHTLINER CUSTOM CHASSIS | Driven By You

Innovations

*Fireside
Chat*

- ▶ V-Ride Rear Suspension System
 - First-ever single drive axle suspension rated 17,500 to 24,000 pounds
 - Designed to carry more gear and luxury amenities
 - Changed the industry and now all Freightliner Chassis are STD with V-Ride
- ▶ UltraSteer
 - Eliminates tire scrub, improves ride & handling
 - Auto-Lock to straight @ 20mph and in reverse for complete control



FREIGHTLINER CUSTOM CHASSIS | Driven By You

See at FCCC booth! Or stay after to see the Videos!

Innovations

*Fireside
Chat*

▶ OptiView

- Influenced by Mercedes-Benz®, OptiView is the first LCD instrument cluster in the RV industry
 - Improved interface and steering wheel controls
 - 360-degree camera system capability and bluetooth connectivity



▶ Roadwatch

- Ultimate RV safety system assisting the driver with control of the coach in all road conditions and maneuvers with:
 - Electronic Stability Control (ESC)
 - Roll Stability Control (RSC)
 - Collision Mitigation (forward and active braking),
 - Adaptive Cruise Control (ACC)
 - Automatic Traction Control (ATC)

ROADWATCH



FREIGHTLINER CUSTOM CHASSIS | Driven By You

Leading Warranty & Coverage

*Fireside
Chat*

ENGINE		
Cummins	5 Years	100,000 Miles
Detroit	5 Years	100,000 Miles
TRANSMISSION		
Allison MH Series	5 Years	200,000 Miles
COMPONENTS		
Chassis	3 Years	50,000 Miles
Drive Train	3 Years	50,000 Miles
Suspension	3 Years	50,000 Miles
Frame Rails & Cross Members	5 Years	100,000 Miles
COVERAGE		
Towing/Roadside Assistance*	3 Years	50,000 Miles

All warranties fully transferable



FREIGHTLINER CUSTOM CHASSIS | Driven By You

Ownership Experience

[Introduction to FCCC](#)

[Chassis Family](#)

[Ownership Experience](#)

[Let's Drive!](#)

[Chassis Care](#)

[What's New](#)



24/7 Direct

*Fireside
Chat*

- ▶ **Lifetime coach support**
 - Not tied to warranty
- ▶ Industry-first 24/7 direct to manufacturer technical support
 - General support
 - Breakdown assistance
 - Technical assistance
- ▶ Call 1-800-FTL-HELP (385-4357) with last 6 digits of VIN
- ▶ Email fccservice@daimler.com
- ▶ Average of 19 years experience across more than 12 call center personnel



FREIGHTLINER CUSTOM CHASSIS | Driven By You

24/7 Direct

Fireside Chat

- ▶ 800-FTL-HELP: your first call
- ▶ Also available for direct contact:
 - Cummins
 - Detroit
 - Allison Transmissions
 - Michelin
 - Goodyear



FREIGHTLINER CUSTOM CHASSIS | Driven By You

24/7 Direct Owner Card

*Fireside
Chat*

- ▶ Owner welcome kit with personalized USB card



- "Knowing Your Chassis"
- DTNAconnect.com
- Service & Operators Manuals
- Warranty Registration and Manuals
- Interactive Service Log
- And more.



FREIGHTLINER CUSTOM CHASSIS | Driven By You

Oasis Dealerships

*Fireside
Chat*

- ▶ While FCCC has over 450 Service points, 90+ Oasis Dealerships in network
- ▶ Amenities focused on RV Owner
 - Owners Lounge
 - Dedicated entrance
 - RV hook ups
- ▶ Visit FCOCRV.org for the select Oasis locations offering discounts to FCOC members



FREIGHTLINER CUSTOM CHASSIS | Driven By You

24/7 Smart Phone App

*Fireside
Chat*

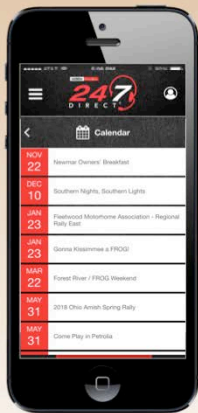

Download on the
App Store

GET IT ON

Google play



Download from
Windows Phone Store

Search:
Freightliner 24/7



FREIGHTLINER CUSTOM CHASSIS | Driven By You

Why seek out Freightliner Service?

*Fireside
Chat*

- ▶ Spartan, PowerGlide and Freightliner owners walk into a Freightliner Service Center...
 - Who gets serviced with speed and savings?
- ▶ Hourly service rate starts...
 - **FCCC VIN – Service Starts Im**
 - Off Brand – Hourly rates start the mo



FREIGHTLINER CUSTOM CHASSIS | Driven By You

Camp Freightliner

*Fireside
Chat*

- ▶ Two-day advanced training workshop in Gaffney, SC at FCCC's Factory Service Center
- ▶ \$235 single, \$285 for couples*
- ▶ VIN Specific Training
- ▶ Lunch included, both days
- ▶ Hook-ups on-site or discounted local camping
- ▶ Enrollment information can be found at:
www.fcccrv.com



FREIGHTLINER CUSTOM CHASSIS | Driven By You

Factory Service Center

*Fireside
Chat*

- ▶ Factory trained technicians
- ▶ Daily Factory tours
- ▶ Full service Oasis Facility
 - 6 service bays
 - 20 RV electrical hookups
 - Official vehicle weight ratings
 - Water and dump site on location
- ▶ Call!
 - 855-253-0421 for appointments



FREIGHTLINER CUSTOM CHASSIS | Driven By You

Owners Club

*Fireside
Chat*

- ▶ Over 10,000 members nationwide
- ▶ First year's membership is FREE
- ▶ \$15 per year or \$70 for 5 years*
- ▶ Exclusive FCOC rallies each year
- ▶ Quarterly newsletter



Owners Club (continued)

*Fireside
Chat*

- ▶ Eligible for the Chrysler Rewards Program.
 - Vehicles for purchase 1% below factory invoice*
- ▶ 5% discount* on parts and labor at Factory Service Center
- ▶ 10% discount* on posted labor rates and back counter parts sales at participating Oasis dealerships
- ▶ Sign up at rallies in the FCCC display or online at: www.fcocrv.org



FREIGHTLINER CUSTOM CHASSIS | Driven By You

4UZ Apparel

*Fireside
Chat*

- ▶ 4UZ – first 3 digits of FCCC RV Chassis VIN numbers
- ▶ 4UZ apparel line launched in 2015
 - Focuses on the RV lifestyle
 - T-shirts, hats, jackets, etc.
- ▶ 4UZRV.com



FREIGHTLINER CUSTOM CHASSIS | Driven By You

Social Media

Fireside Chat



RV Road Trippers

RV Road Trippers
@DriveFCCC

Home
About
Photos
Reviews
Videos
Events
Notes
Posts
Community

552 Hyatt St
Gaffney, South Carolina
29341

(864) 487-1700

Contact RV Road Trippers
via Messenger

www.fcccrv.com

Travel Company - Travel
Service



@DriveFCCC

DriveFCCC

These games are a great way to break up the drive time and have some fun while traveling! [cwljyGQ283D1LMfv](#)

Happy Fourth of July! We hope you have a fun and safe holiday with your friends and family.



FREIGHTLINER CUSTOM CHASSIS | Driven By You

FCCC Website

*Fireside
Chat*

The screenshot shows the homepage of the Freightliner Custom Chassis website. The top navigation bar is red with white text for 'CHASSIS', 'COACHES', 'PARTS & SERVICE', 'FCCC', and 'OWNERS'. The main content area features a large image of a motorhome chassis with the text 'PERFORMANCE. SAFETY. INNOVATION.' and a paragraph describing the technology and engineering. Below this is a 'TOUR THE XC' button. At the bottom, there are four icons representing different services: '24/7 DIRECT', 'DAIMLER Custom Chassis', and 'CAMP FREIGHTLINER'. Navigation buttons for 'EXPLORE COACHES' and 'GET SERVICE' are at the very bottom.

FCCCRV.com

The screenshot shows the 'Driven By You' page on the Freightliner Custom Chassis website. The page features a large image of a motorhome chassis with the text 'Driven By You' and a paragraph describing the company's commitment to quality and innovation. Below this is a 'TOUR THE XC' button. The page also includes a section for 'DAIMLER Trucks North America Launches Reimagined NACV Show with Innovative Vehicle Lineup, Technological Leadership' and a 'CAMP FREIGHTLINER' logo. Navigation buttons for 'EXPLORE COACHES' and 'GET SERVICE' are at the bottom.

FreightlinerChassis.com



FREIGHTLINER CUSTOM CHASSIS | Driven By You

Let's Drive!

[Introduction to FCCC](#)

[Chassis Family](#)

[Ownership Experience](#)

[Let's Drive!](#)

[Chassis Care](#)



Ride & Handling

*Fireside
Chat*

▶ **What is the easiest way to:**

ANSWER

- Improve Your Ride?
- Decrease Your Tire Wear?
- Improve Your Road Handling?
- Improve Your Braking?



FREIGHTLINER CUSTOM CHASSIS | Driven By You

Ride & Handling

*Fireside
Chat*

► **What is the easiest way to:**

- Improve Your Ride?
- Decrease Your Tire Wear?
- Improve Your Road Handling?
- Improve Your Braking?

ANSWER

Correct Tire Pressure!



FREIGHTLINER CUSTOM CHASSIS | Driven By You

Ride & Handling

*Fireside
Chat*

- ▶ How to determine the correct tire pressure
- ▶ Weigh each wheel position
- ▶ Set tire pressure according to chart

S = 1 tire on 1 side of single axle	
D = 2 tires on 1 side of dual axle	
For Tag axle, use applicable Single or Dual chart	

LF: 5,300 LBS RF: 5,450 LBS
LR: 9,500 LBS RR: 9,350 LBS

275/80R22.5 LRG

XZA3[®]

PSI	70	75	80	85	90	95	100	105	110	
kPa	480	520	550	590	620	660	690	720	760	
LBS	SINGLE	4500	4725	4940	5155	5370	5510	5780	5980	6175
	DUAL	8190	8600	9080	9380	9770	10140	10520	10880	11350
kPa	SINGLE	2040	2140	2240	2340	2440	2500	2620	2710	2800
	DUAL	3720	3900	4120	4260	4440	4600	4780	4940	5150

**** Cold Inflation Pressures**



FREIGHTLINER CUSTOM CHASSIS | Driven By You

Ride & Handling

*Fireside
Chat*

Weight Distribution

- ▶ Some of the common effects of improper weight distribution include:
 - Front-end wandering
 - Coach porpoise
 - Driver fatigue

- ▶ Front-to-rear weight distribution should be as close to equal percentages as possible



Coach is tuned for 80% to 100% capacity for optimum ride.



FREIGHTLINER CUSTOM CHASSIS | Driven By You

Transmission

*Fireside
Chat*

- ▶ For normal driving and best fuel economy
 - Select “D” and “Mode On”
 - Use all the time.
- ▶ For performance
 - Select “Mode Off”



FREIGHTLINER CUSTOM CHASSIS | Driven By You

Transmission

*Fireside
Chat*

- ▶ 3000/4000 MH Allison Transmission

On 2010 EPA or Newer:

- ▶ Press up and down arrow keys simultaneously
- ▶ Wait for two-minute “countdown”
- ▶ Display indicates – OL (oil level)
 - “OL – OK” indicates good oil level
 - “OL – HI” followed by number indicates quarts over-filled
 - “OL – LO” followed by number indicates quarts under-filled
 - “OL – 70” means transmission is not up to operating temperature



FREIGHTLINER CUSTOM CHASSIS | Driven By You

Air System

*Fireside
Chat*

Ease of Maintenance

Red: Front brakes (secondary)

Green: Rear brakes (primary)

Black: Air tank supply &
Emergency park brake system

Blue: Air suspension system

White: Air suspension exhaust

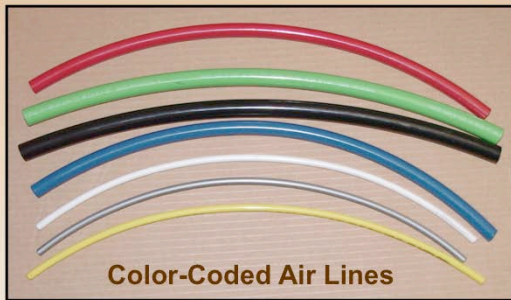

Options:

Silver: Air system governor control

Yellow: Park brake control supply & optional system supply

Push-to-connect fittings are standard



FREIGHTLINER CUSTOM CHASSIS | Driven By You

Compressed Air System

*Fireside
Chat*

- ▶ Heated automatic moisture ejector system
 - Inside air dryer
 - On the wet tank

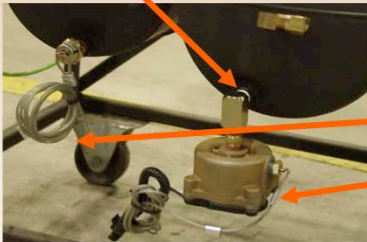

- Drain lanyards should be pulled every 6 months for 10 to 15 seconds
- Manual drain lanyards

Note: There are three drain lanyards. Only two are shown.



FREIGHTLINER CUSTOM CHASSIS | Driven By You

Bendix AD and SS Series Dryers

*Fireside
Chat*

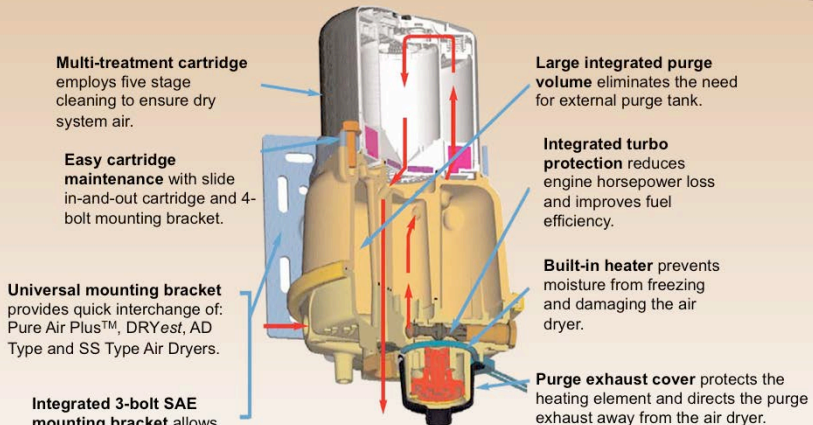

Multi-treatment cartridge employs five stage cleaning to ensure dry system air.

Easy cartridge maintenance with slide in-and-out cartridge and 4-bolt mounting bracket.

Universal mounting bracket provides quick interchange of: Pure Air Plus™, DRYest, AD Type and SS Type Air Dryers.

Integrated 3-bolt SAE mounting bracket allows for easy installation in OEM and existing applications.

Large integrated purge volume eliminates the need for external purge tank.

Integrated turbo protection reduces engine horsepower loss and improves fuel efficiency.

Built-in heater prevents moisture from freezing and damaging the air dryer.

Purge exhaust cover protects the heating element and directs the purge exhaust away from the air dryer.

**Change every
36 months**



FREIGHTLINER CUSTOM CHASSIS | Driven By You

Auxiliary Air Supply

*Fireside
Chat*

- ▶ Manifold provided for auxiliary air source
 - Up to 120 psi
- ▶ Can be used for:
 - Air horn supply
 - Fill tires
 - etc.
- ▶ The only approved location for tying into the air system



FREIGHTLINER CUSTOM CHASSIS | Driven By You

Brakes

*Fireside
Chat*

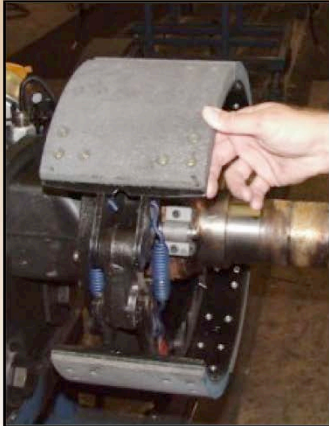

- ▶ Rear brakes act as parking brake
 - Spring-applied
 - Holding power of two large drum brakes
 - Park brake will not release in event of air pressure loss
- ▶ In the event of an air pressure loss
 - Warning lamp and buzzer will warn you



- ▶ Equipped with automatic slack adjusters



FREIGHTLINER CUSTOM CHASSIS | Driven By You

Disc Brakes

*Fireside
Chat*

Front: 17" Disc Rotors

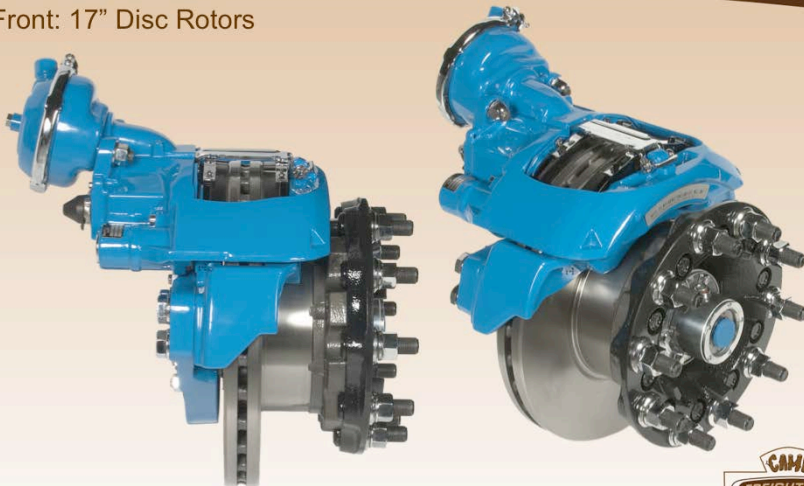

FREIGHTLINER CUSTOM CHASSIS | Driven By You

Engine Brakes

*Fireside
Chat*

- ▶ Improve braking power
- ▶ Reduce chance of overheating of service brakes on steep grades
- ▶ Work in conjunction with Allison electronic transmissions
- ▶ Illuminate brake lamps with 5- and 6-speed transmissions



VGT



Exhaust Brake



Compression Brake



FREIGHTLINER CUSTOM CHASSIS | Driven By You

Engine Brakes: Compression Brake

*Fireside
Chat*

- ▶ Equipped on Cummins L9, X12, X15, Detroit DD13
- ▶ Turns the energy-producing engine into an energy-absorbing air compression brake
- ▶ Two switches: one on/off, one braking power level

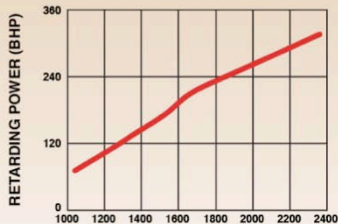

RPM



FREIGHTLINER CUSTOM CHASSIS | Driven By You

SmartWheel

*Fireside
Chat*



(3)



(2)

(1)

A



(4)

(5)

(6)

B

- ▶ Left and Right switch panels for cruise control, headlight and marker lamp interrupt and wiper controls



FREIGHTLINER CUSTOM CHASSIS | Driven By You



Check Engine Indicator



Generator On



High Exhaust System Temperature (HEST) Lamp



Stop Engine Warning



Dash Driver Display Screen



Malfunction Indicator Lamp



ABS Indicator



Check Transmission



Cruise-On
Indicator



Engine Brake Engaged Indicator



Left-Turn
Signal
Arrow



Diesel Particulate Filter
(DPF) Lamp

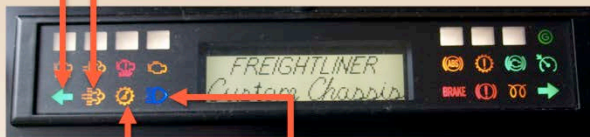

Shift Inhibit
Indicator Lamp



Headlight High-Beam
Indicator Lamp



Parking Brake Indicator



Low Air Pressure Indicator



Wait to Start Indicator



Right-Turn Signal Arrow



OptiView

*Fireside
Chat*



- ▶ Industry's first fully integrated, all-digital LCD instrument cluster
- ▶ Available on select models – see manufacturer's specifications



FREIGHTLINER CUSTOM CHASSIS | Driven By You

Roadwatch

*Fireside
Chat*

OPTIVIEW™ ROADWATCH



- ▶ **The Ultimate RV Safety System** – Electronic Stability Control, Roll Stability Control, Automatic Traction Control, Collision Mitigation, Adaptive Cruise Control
- ▶ Available on select models – see manufacturer’s specifications



FREIGHTLINER CUSTOM CHASSIS | Driven By You

Comfortable Ride

*Fireside
Chat*

- ▶ TRW Infinitely Adjustable Tilt & Telescoping Steering Column
- ▶ Optional Comfort Drive (see notes)

Foot Pedal Control

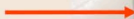

FREIGHTLINER CUSTOM CHASSIS | Driven By You

Confident Handling

*Fireside
Chat*

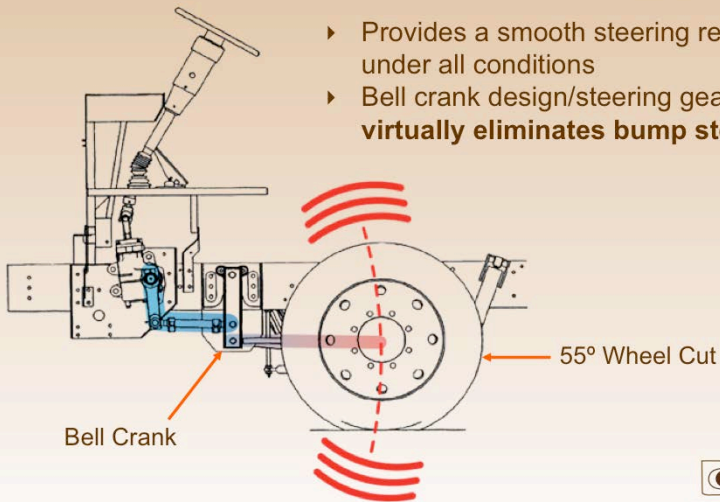

FREIGHTLINER CUSTOM CHASSIS | Driven By You

Confident Handling

*Fireside
Chat*

Competitor



Without bell crank, competitive chassis are subject to **Bump Steer**

FCCC



FCCC has **NONE**
Diesel is Easy!



FREIGHTLINER CUSTOM CHASSIS | Driven By You

Chassis Care

[Introduction to FCCC](#)

[Chassis Family](#)

[Ownership Experience](#)

[Let's Drive!](#)

[Chassis Care](#)

[Freightlineage](#)



Scheduled Maintenance

*Fireside
Chat*

- ▶ 6,000 miles or 6 months initial maintenance
- ▶ After your initial 6-month maintenance, the recommendation is service every 12 months
- ▶ Generator Service
- ▶ Maintenance schedule available at FCCCRV.com or in your maintenance manual



FREIGHTLINER CUSTOM CHASSIS | Driven By You

Scheduled Maintenance

*Fireside
Chat*

Lubrication Points

Lubrication Points

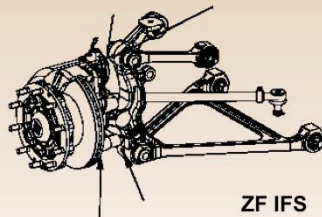
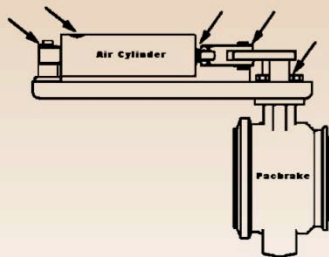

ZF IFS



FREIGHTLINER CUSTOM CHASSIS | Driven By You

Scheduled Maintenance

*Fireside
Chat*

Lubrication Points

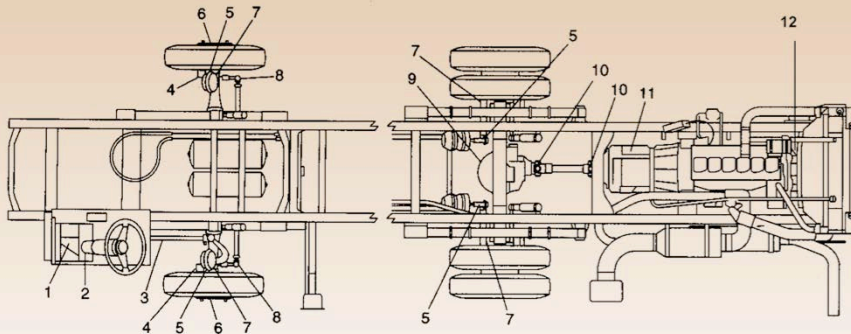

03/03/98

f310587



FREIGHTLINER CUSTOM CHASSIS | Driven By You

Scheduled Maintenance

*Fireside
Chat*

▶ Grease fittings

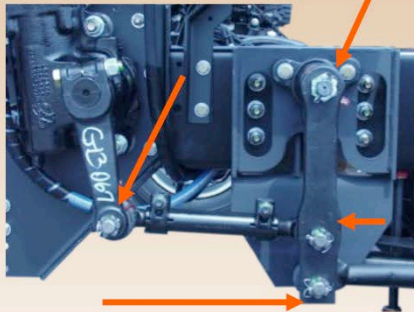

Front oil-filled bearing

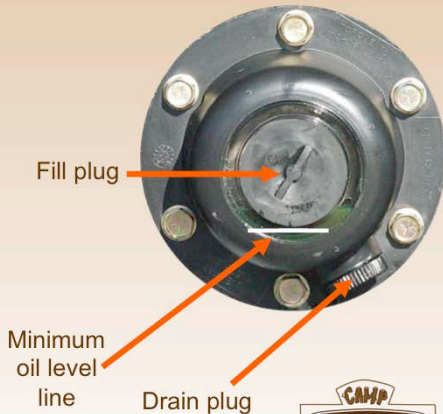

Pre-Trip Inspection

*Fireside
Chat*

- ▶ Check tires
- ▶ Look for fluid leaks



FREIGHTLINER CUSTOM CHASSIS | Driven By You

Pre-Trip Inspection

*Fireside
Chat*

- ▶ Check coolant level



**Before 2001
production**
910 square inch
rear radiator



Pre EPA 2007 Side radiator



EPA 2007 and 2010
1050 square inch rear radiator



FREIGHTLINER CUSTOM CHASSIS | Driven By You

Pre-Trip Inspection

*Fireside
Chat*



← Check transmission fluid level

Check engine oil level →



← Check for animals in engine compartment

Check hydraulic brake fluid (FRED) →



FREIGHTLINER CUSTOM CHASSIS | Driven By You

Pre-Trip Inspection

*Fireside
Chat*

- ▶ Check hydraulic steering fluid*
 - Refer to owner's manual



910 square inch
rear radiator

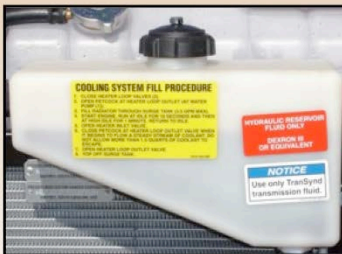

1000 square inch or larger
rear radiator

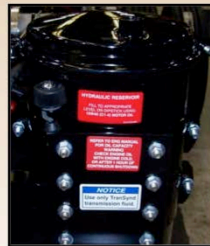

Side radiator



Pre-Trip Inspection

*Fireside
Chat*

- ▶ Check fuel and water separator



FREIGHTLINER CUSTOM CHASSIS | Driven By You

Pre-Trip Inspection

*Fireside
Chat*

- ▶ Check air filter restriction indicator
 - Air cleaners are often the most neglected part

Brand-new air cleaner
10" to 12" of vacuum



FREIGHTLINER CUSTOM CHASSIS | Driven By You

Towing Guidelines

*Fireside
Chat*

- ▶ Always tow from the front
- ▶ Remove the drive shaft
- ▶ Release the brakes / Air up suspension
- ▶ Lifting by tires is preferred
- ▶ When in doubt...1-800-FTL-HELP



FREIGHTLINER CUSTOM CHASSIS | Driven By You

Fireside Chat

Happy Trails.



FREIGHTLINER CUSTOM CHASSIS | Driven By You